

Four Basic Concepts

Part 1

An aerodyne is defined as any heavier-than-air aircraft which derives lift from motion. The history of aviation is filled with a nearly infinite number of aerodyne planforms, each formulated to achieve the designer's goals.

We've described a multitude of tailless designs over the past five years — from swept back, through “plank,” to swept forward planforms — and in the process have examined airfoils, twist formulae, and the effects of sweep and twist on both stability and performance.

Longitudinal stability is probably the foremost concern in the designer's mind as a tailless planform takes shape. This is because successful tailless aircraft are the result of a careful balance of center of gravity, overall pitching moment, and wing twist.

Most designers find it helpful to have some basic logical and consistent “rules of thumb” to rely on during the design process. This series of articles will endeavor to examine and explain four fundamental design rules so they are easily remembered and thus be an inherent part of the tailless designer's thought processes.

We'll begin with a brief outline of the four important concepts to be considered during the design process: (1) center of gravity, (2) pitching moment, (3) sweep angle, and (4) design lift coefficient.

The following points apply to tailless planforms. For simplicity, Figures 1, 2 and 4 show only an airfoil section.

(1) Center of Gravity

Stability is dependent upon the location of the center of gravity — the more forward the center of gravity, the more stable the aircraft. The term stability factor, or static margin, denotes the distance between the center of gravity and the aerodynamic center. The aerodynamic center lies at 25% of the mean (average) aerodynamic chord. Stability factor, or static margin, is defined in terms of percent of mean (average) chord as well. A stability factor of 0.035,

for example, places the center of gravity at $0.215\bar{c}$; that is, $3.5\bar{c}$ ahead of the aerodynamic center which lies at 25% .

$$0.25 - 0.035 = 0.215$$

If the center of gravity is at the neutral point (aerodynamic center), the stability factor is zero, and the aircraft will not recover from a stall but will instead descend like a parachute, or like it is dethermalized. The static margin provides the restoring moment needed to bring the stalled wing out of the stall. In normal flight, therefore, with a positive static margin, the nose of the aerodyne is being constantly pushed down because the center of gravity is ahead of the aerodynamic center. For controlled flight there must be an opposing force, otherwise the airfoil will be rotated nose down. See Figure 1.

While the force pushing the nose down is independent of air speed, the opposing aerodynamic force is directly related to air speed. Thus, the nose drops as air speed decreases and rises as air speed increases.

The more forward the center of gravity, the more stable the planform. (This is true even if the center of gravity is behind the aerodynamic center. In this case, moving the center of gravity forward increases the aerodyne's stability, although the aerodyne itself is still unstable. As a general rule, so long as the planform is not changed, more twist will be needed as the center of gravity is moved forward.

(2) Pitching Moment

If the wing utilizes a conventional airfoil it tends to rotate nose down during flight because of airfoil section camber as depicted in Figure 2. This will continue into a tumbling action. For controlled flight there must be a counteracting force.

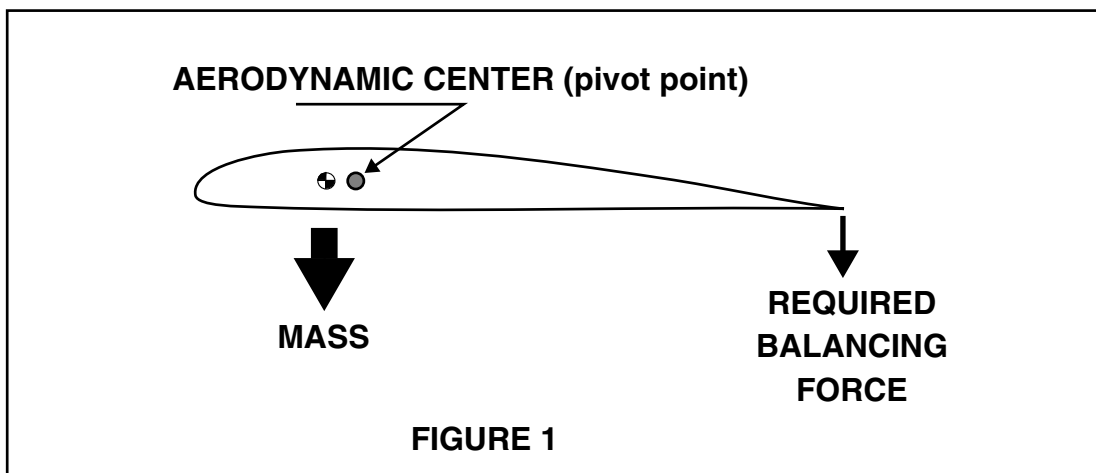

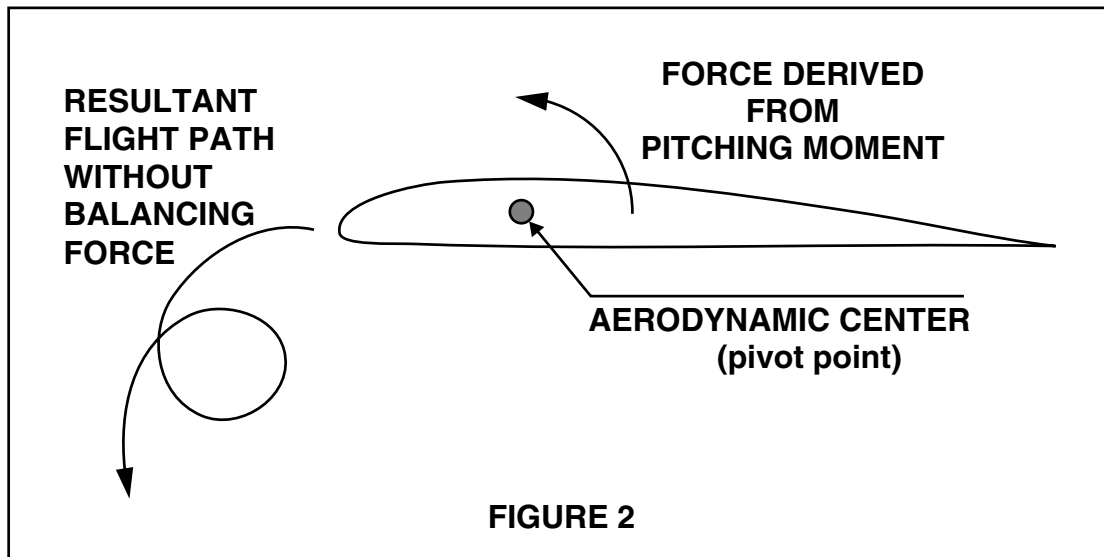

Conventional high lift sections usually have strong negative pitching moments. If one of these high lift section is used at the root, a strong aerodynamic force must be produced by the wing tip to counteract the pitching moment of the root section. This is accomplished by increasing wing twist or by changing the wing tip airfoil. Since both the wing root and the wing tip are traveling at the same speed, all of the generated aerodynamic forces are always directly proportional to each other.

(3) Sweep Angle

If the stability factor (static margin) remains constant, increased sweep reduces the required twist. This is because a larger sweep angle places the wing tip further away from the aerodynamic center, providing a larger moment arm. A couple of things to keep in mind, however...

First, rearward sweep is notorious for making winch launching difficult. This is because any yaw produces a powerful rolling force at high angles of attack. Making a small cardboard model of a swept wing planform will assist in understanding how this happens. Simply hold the cutout in front of you, viewing it as if you are standing at the turnaround. Hold the model at a moderate pitch so you are looking at the bottom of the wing. Then rotate the wing in the yaw axis. You will see the forward wing project a relatively larger lifting surface than the retreating wing. This larger lifting surface induces a strong roll moment which cannot be easily overcome by control surface movement. Several designers have gone to zero dihedral to control this yaw-roll problem, while others have utilized anhedral.

Second, increased forward sweep requires a larger fin area for directional (yaw) stability. This is the result of sweep forward being a destabilizing factor. To visualize this, take the cardboard outline used in the previous example and view it from above. Now imagine the wing, with the wing tips forward, yawing slightly. Notice the retreating wing increases in effective span while the advancing wing decreases in effective span. In the case of a moderate forward sweep angle, the drag differential is substantial, and only a large fin can keep the wing in a relatively straight flight path.

Additionally, the retreating wing will produce more lift, inducing a rolling moment opposite to the yaw. Dihedral can at least partially overcome this effect by producing an oppositional force, just as when a conventional tailed sailplane with dihedral but lacking ailerons enters a rudder induced turn.

(4) Design Lift Coefficient

Wing twist must additionally be adjusted to hold the entire wing at the angle of attack required to attain the desired C_L . The angle of attack must increase to achieve a larger design C_L , and increased wing twist is required to hold the entire wing at the proper angle of attack.

It should be noted that large amounts of twist are detrimental to performance due to increased drag. Wing twist should be used to obtain the $C_{L_{cruise}}$, not $C_{L_{max}}$ or $C_{L_{thermal}}$. High and low flight speeds are achieved through control surface trim. This results in the lowest overall trim drag.

In condensed form, here are the four basic rules which must be kept in mind during the design process:

- (1) increased stability (a more forward CG) requires more twist
- (2) a larger $C_{m_{root}}$ requires more twist
- (3) decreased sweep angle requires more twist
- (4) a larger design C_L requires more twist

Dr. Walter Panknin presented a set of equations at the 1989 MARCS Symposium which covers both the location of the center of gravity and the required wing twist for any tailless planform.

Note the four basic rules regarding center of gravity, pitching moment, sweep angle, and design lift coefficient outlined previously are all included in Dr. Panknin's formula within Equation 2. This equation also takes into account taper ratio and aspect ratio, but we will not be discussing these two variables here.

$$\alpha_{\text{geo}} = \alpha_{\text{total}} - (\alpha_{10\text{root}} - \alpha_{10\text{tip}}) \quad \text{Equation 1}$$

where;

α_{geo} = geometric twist angle, used for construction
 $\alpha_{10\text{root}}$ = zero lift angle, root
 $\alpha_{10\text{tip}}$ = zero lift angle, tip

and

$$\alpha_{\text{total}} = \frac{(K_1 * C_{\text{mr}} + K_2 * C_{\text{mt}}) - C_L * \text{sf}}{1.4 \cdot 10^{-5} * A^{1.43} * \beta} \quad \text{Equation 2}$$

where;

$K_1 = 1/4 * (3 + 2t + t^2)/(1 + t + t^2)$
 t = taper ratio, c_r/c_t
 c_r = chord, root
 c_t = chord, tip
 C_{mr} = moment coefficient, root
 $K_2 = 1 - K_1$
 C_{mt} = moment coefficient, tip
 C_L = overall coefficient of lift with neutral trim
 sf = stability factor (static margin)
 A = aspect ratio, b/\bar{c}
 b = wingspan
 \bar{c} = average chord; $(c_r + c_t)/2$
 β = sweepback angle of 1/4 chord line;
+ for sweep back, - for sweep forward

This formula has proven to be very accurate. Other than the dimensions of your creation, you need only know the zero lift angle and moment coefficient of the root and tip airfoil sections you will be using. Computer programs which utilize Dr. Panknin's formula have been available for some time. Once the necessary information is input, the computer will provide all of the additional data you need to build a longitudinally stable tailless sailplane. The necessary computations can also be accomplished on a scientific calculator.

Despite basic knowledge of model aircraft design and very good mathematical formulae, however, it remains difficult for the modeler to visualize the complex relationships between center of gravity, moment coefficients, twist and sweep, and mentally formulate an effective tailless planform for a specific task.

In response, Bill Kubiak, our Minnesota friend, suggested we attempt to integrate the basic trends into graphical form. He recommended focusing on the required twist angle by maintaining a “generic” design with predefined dimensions which would remain constant. Each of a series of graphs would then depict a specific root and tip airfoil combination. With sweep angle being the only variable within each graph, readers would be able to see the relationships between planform and necessary twist in a pictorial fashion which would be easily comprehended and easily remembered.

Following Bill's recommendation, we'll begin by defining those dimensions which remain constant. See Table 1 for this information. It should be noted that the chosen design C_L is relatively high. This was done for graphical purposes only. In practice, the design C_L would be significantly lower.

PARAMETER	DIMENSION
span, b	100"
semispan, b/2	50"
root chord, cr	12"
tip chord, ct	8"
average chord, \bar{c}	10"
taper ratio, t	8/12 = 0.67
stability factor, sf, or static margin, SM	0.035
design lift coefficient, C_L	0.6
leading edge sweep	variable, in increments of five degrees, from -20 degrees to + 20 degrees
quarter chord line sweep	variable, from - 21 degrees to +18.98 degrees

Table 1

Figure 3 shows the nine planforms used to generate all of the graphical data included here.

Since this wing is tapered, the quarter chord line does not lie parallel to the leading edge. While it is easier for most people to relate to the leading edge angle, Dr. Panknin's formula uses the angle of the quarter chord line. Table 2 shows the relationship between these two variables. As you can see, the quarter chord angle is always about one degree forward of the leading edge angle.

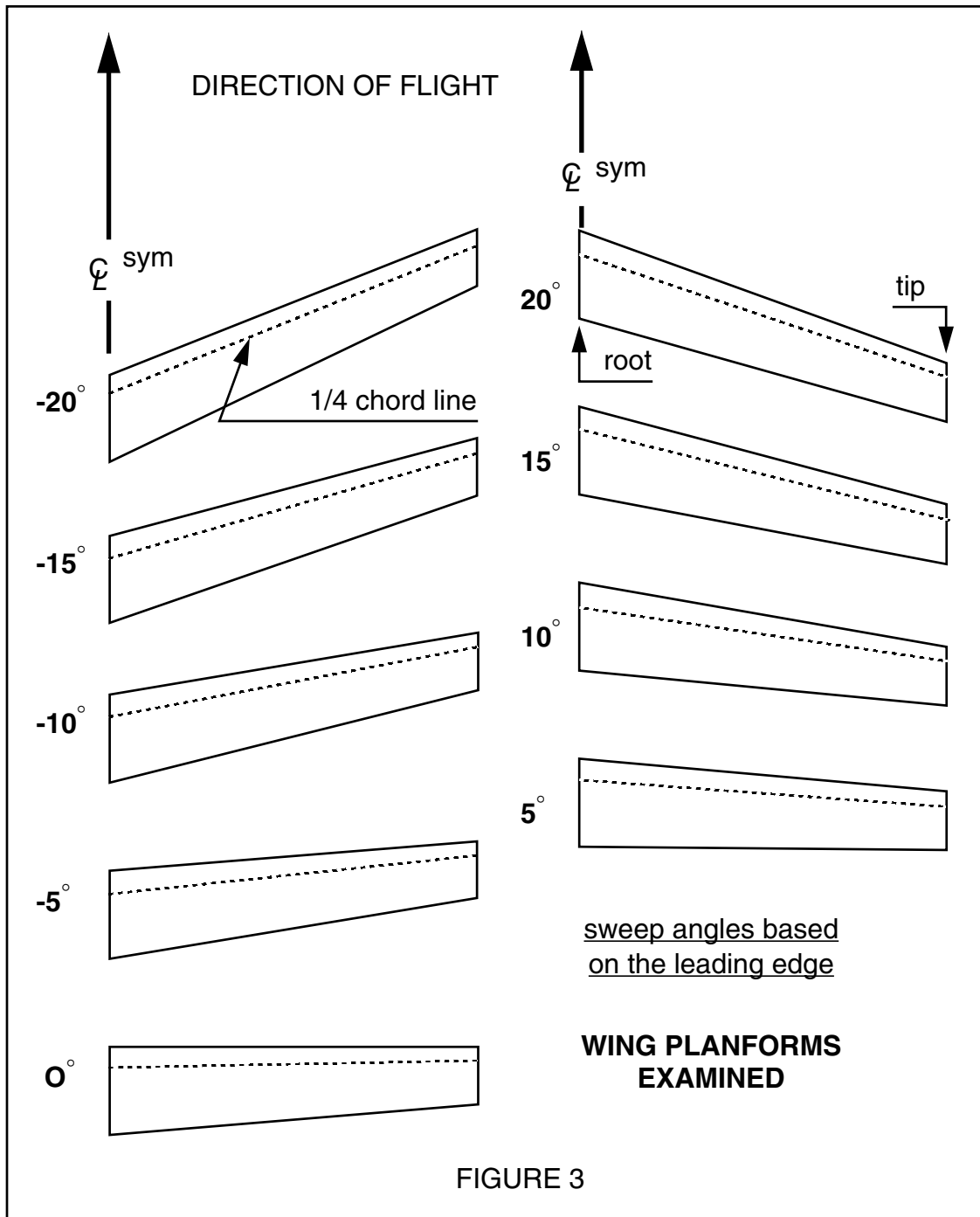

The graphs, which will begin in next month's installment, are based on the leading edge angle. We did this so designs like Jim Marske's Pioneer planform, with its straight leading edge, could be easily evaluated. If you follow the examples by computing the Panknin equations you'll need to use the quarter chord line angle from Table 2.

LE	-20	-15	-10	-5	0	5	10	15	20
1/4 chord	-21.00	-16.06	-11.11	-6.13	-1.15	3.86	8.88	13.93	18.98

Table 2

In Part 2 we will begin our graphical examination of the effects of sweep angle and chosen airfoils (See Table 3) on wing twist.





REF	DESIGNATION	C_m	a_{l0}	SECTION PROFILE
1	E 205	-0.046	-2.37	
2	E 205.inv	+0.046	+2.37	
3	Symmetrical	0.000	0.00	
4	EH 2/10	+0.00165	-0.74	
5	E 228	+0.0143	+0.34	
6	E 230.Eppler/MTB 1/2	+0.053	+1.73	
7	E 230.Panknin	+0.025	+1.73	

Table 3

Part 2

We begin our examination of the effects of specific airfoils and sweep angles on the wing twist needed for a predefined amount of stability and predetermined design C_L . For all of the cases examined here, the static margin (stability factor, sf) is 0.035 and the design C_L is 0.6, a value larger than would likely be used in practice.

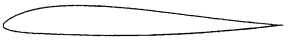
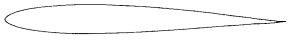
Bill Kubiak, instigator of this exercise, was specifically interested in the effects of sweep on twist when the airfoil used is a flat-bottomed section, but as a reference point we will first look at using a symmetrical section. Graph 1 depicts the case where both the root and tip airfoil are symmetrical. In this case the specific symmetrical airfoil used is unimportant, as both the pitching moment and zero lift angle of any symmetrical section are equal to zero. (Symmetrical section: $C_m = 0.0$, $\alpha_{l0} = 0.0$)

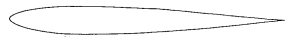
Hans Jürgen Unverferth used a symmetrical Quabeck section for his “Just in Time,” a high performance swept wing design. The major problem with using symmetrical sections on swept tailless designs has always been their relative

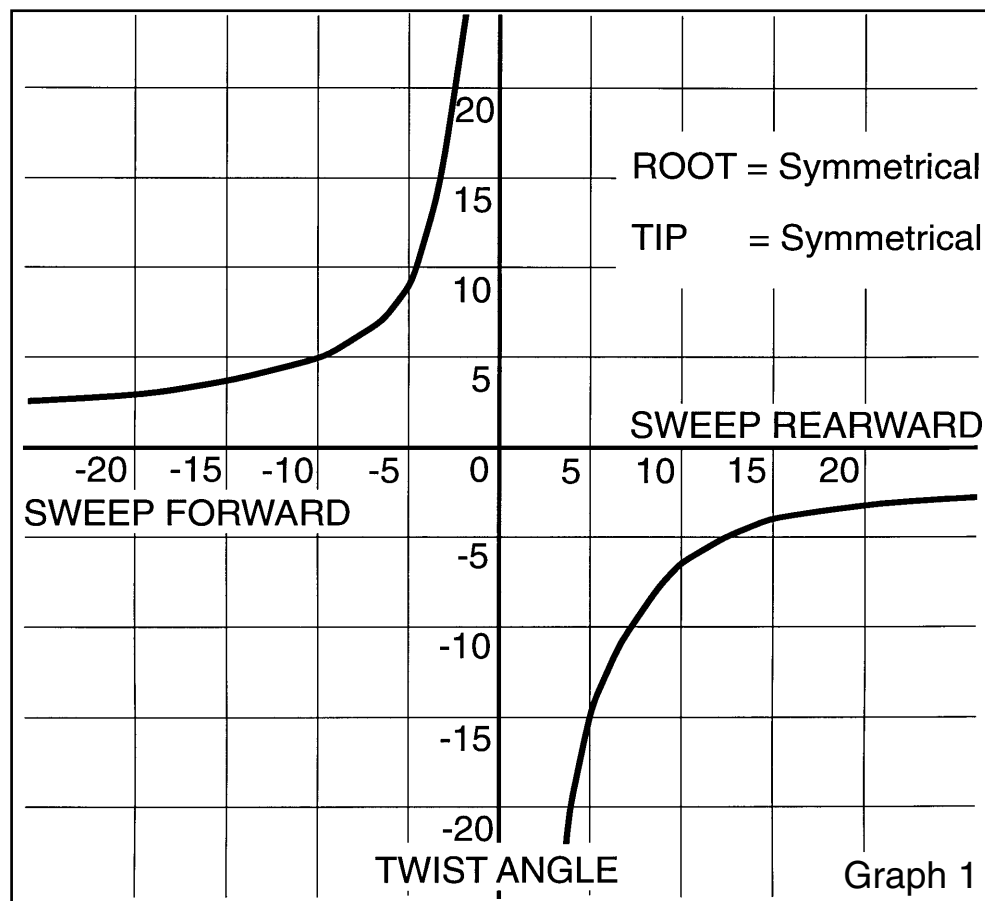

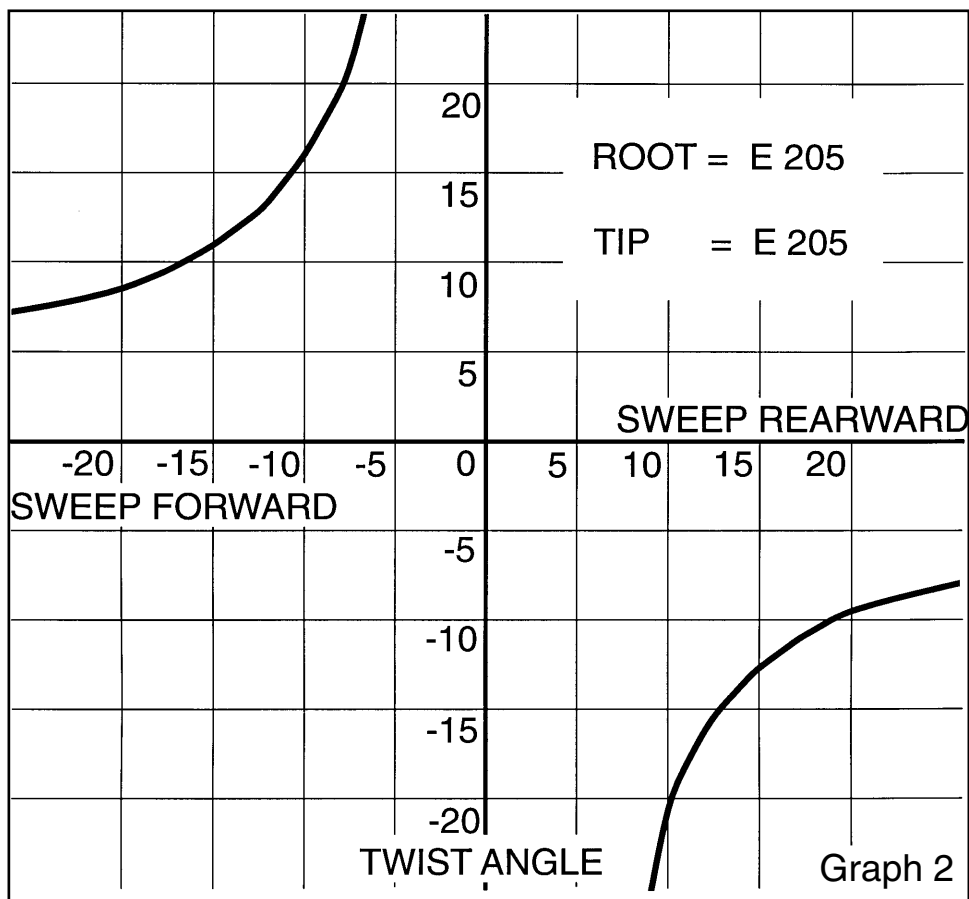

inability to provide large amounts of lift. Until recently, this shortfall was also true of non-symmetrical sections with very low pitching moments. This situation is changing, however, and there are now very low pitching moment sections easily capable of $C_l = 1.0$ and more. The EH series of airfoils provides several excellent examples of the state of the art and will be discussed later.

Turning to the specific case of a flat bottomed section, we chose the Eppler 205 for both the root and tip sections. (E 205: $C_m = -0.046$, $\alpha_{10} = -2.37$) The results are shown in Graph 2.

There are a few things to be learned here:

- For equal angles of forward and rearward sweep, twist angles are of nearly identical magnitude. In fact, if Graph 1 was based on the 1/4 chord line instead of the leading edge, the magnitudes would be exactly equal for equivalent sweep angles. This is due to the root and tip sections having identical zero lift angles. As the zero lift angles become more dissimilar, differences in twist magnitudes become larger.

- As the sweep angle approaches zero degrees the twist angle approaches a truly unmanageable value. Since the twist angle is extremely large as the sweep angle becomes less than 20 degrees, we are driven to find another method of obtaining needed stability when the sweep angle is less than this value. We'll focus on this point later.
- The twist angle decreases as sweep angle increases, but the twist angle never reaches zero degrees. Additionally, the twist angle is large even when the sweep angle is over 20 degrees. Such large sweep angles make winch launches extremely difficult, as we mentioned previously, and cross-span flow becomes a major problem during certain flight regimes. With rearward sweep the tip section is at a severe negative angle. This may lead to stalling of the lower surface under some conditions.
- In the case of sweep back, the wing tip must provide a down force which can both overcome the pitching moment of the root section and hold the root section at a positive angle of attack to achieve the design C_L . But the wing tip in this case has a negative pitching moment, so it contributes, along with the wing root, to rotating the wing forward and downward. This is the reason such a very large twist angle is needed when both the root and tip utilize the E 205 section.
- The negative pitching moment of the wing tip is also a detriment when the wing is swept forward.

The most obvious difficulty in using the E 205 section for both the root and tip is the large amount of wing twist required for wings with sweep back. This problem can be minimized by using a tip section having a positive pitching moment and which is capable of providing significantly more negative lift. A positive pitching moment, combined with an ability to produce a large amount of negative lift provides the potent downforce required by the chosen root section.

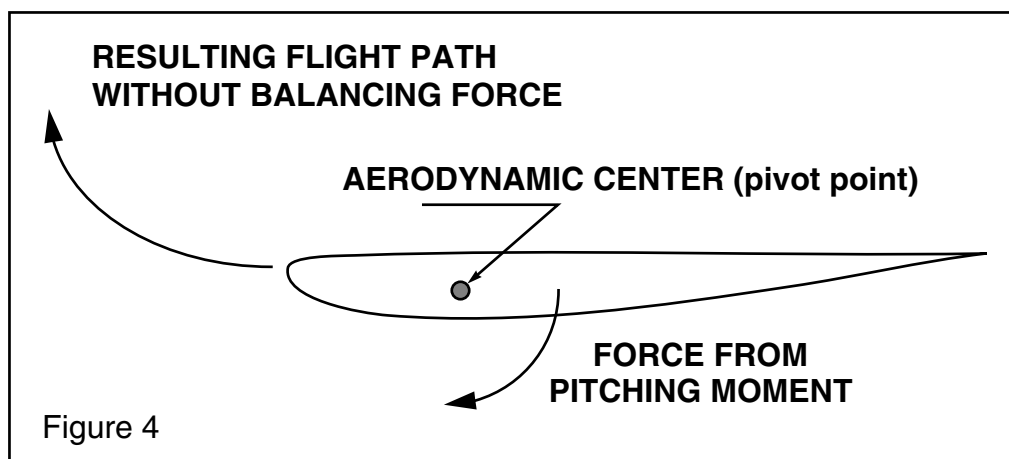

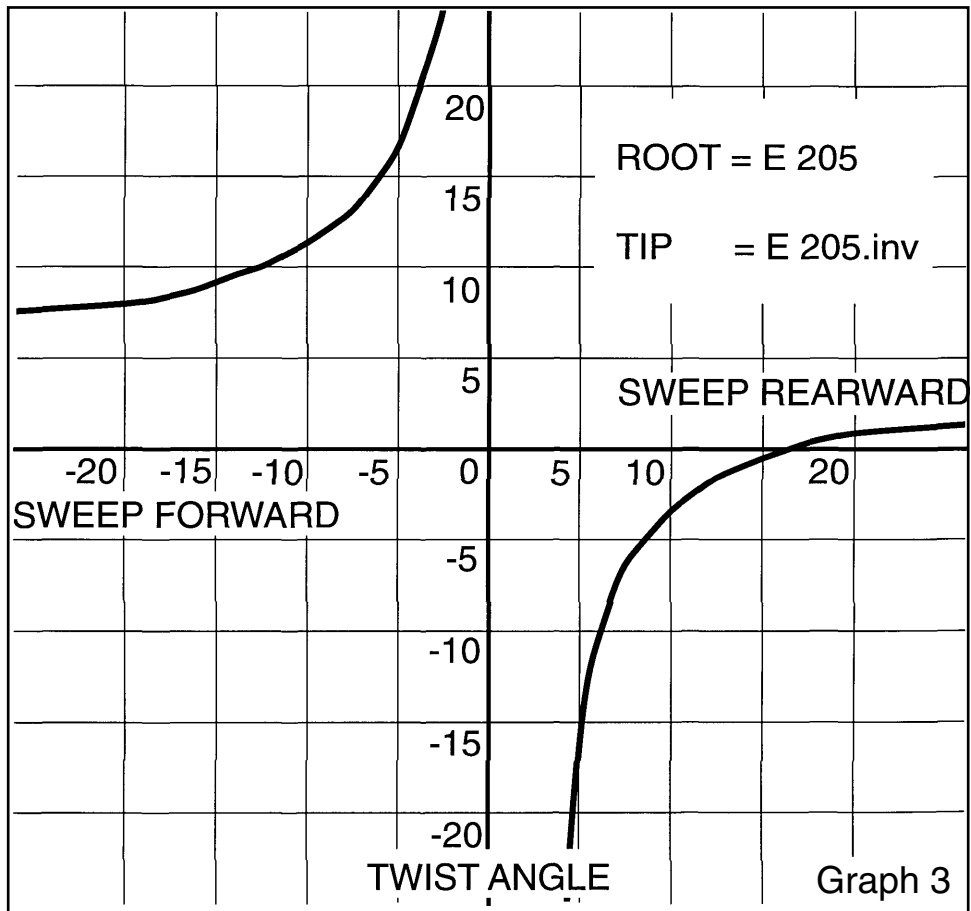

All of this can be accomplished by inverting the E 205 tip section. The pitching moment of the inverted section is positive and this contributes to stability and assists in holding the wing root at the proper angle of attack. Additionally, the airfoil is now capable of producing very large amounts of downward lift because the camber line is oriented appropriately. (E 205.inv: $C_m = +0.046$, $\alpha_{10} = +2.37$) See Figure 4.

Graph 3 shows the startling effects of this simple change of tip section. The twist angle becomes 0° when sweep back is at about 17° , and actually becomes positive for larger sweep angles.

A surprising outgrowth of using the inverted E 205 for the tip section is the reduced twist required for the forward sweep configuration. This is due to the positive pitching moment of the inverted section. Note, however, that the required twist is approximately eight degrees for the case of 20° leading edge sweep; this is probably beyond the point where the relatively flat upper surface will be stalled.

The relationship between pitching moment and required wing twist has been demonstrated to be an important consideration during the design process. As we've seen, a change of tip section can easily bring wing twist values down to manageable levels. However, using a root section with a very low pitching moment is an attractive alternative because very little twist will be required to obtain needed stability. The trick is to choose an airfoil with a near zero pitching moment which is capable of high lift. This is not possible with the symmetrical sections, but the EH series which we mentioned previously provides some excellent candidates.

We'll use the EH 2/10 for both the root and tip sections. (EH 2/10: $C_m = 0.00165$, $\alpha_{10} = -0.74$) Graph 4 depicts twist angle versus sweep angle for this airfoil combination.

Note the small twist angles required — about 25% of the twist angle required for the E 205 - E 205 combination. Additionally, we can anticipate very low drag for the EH 2/10 - EH 2/10 configuration, and, as is typical of low pitching moment airfoils, only very small increases in drag for various trim conditions.

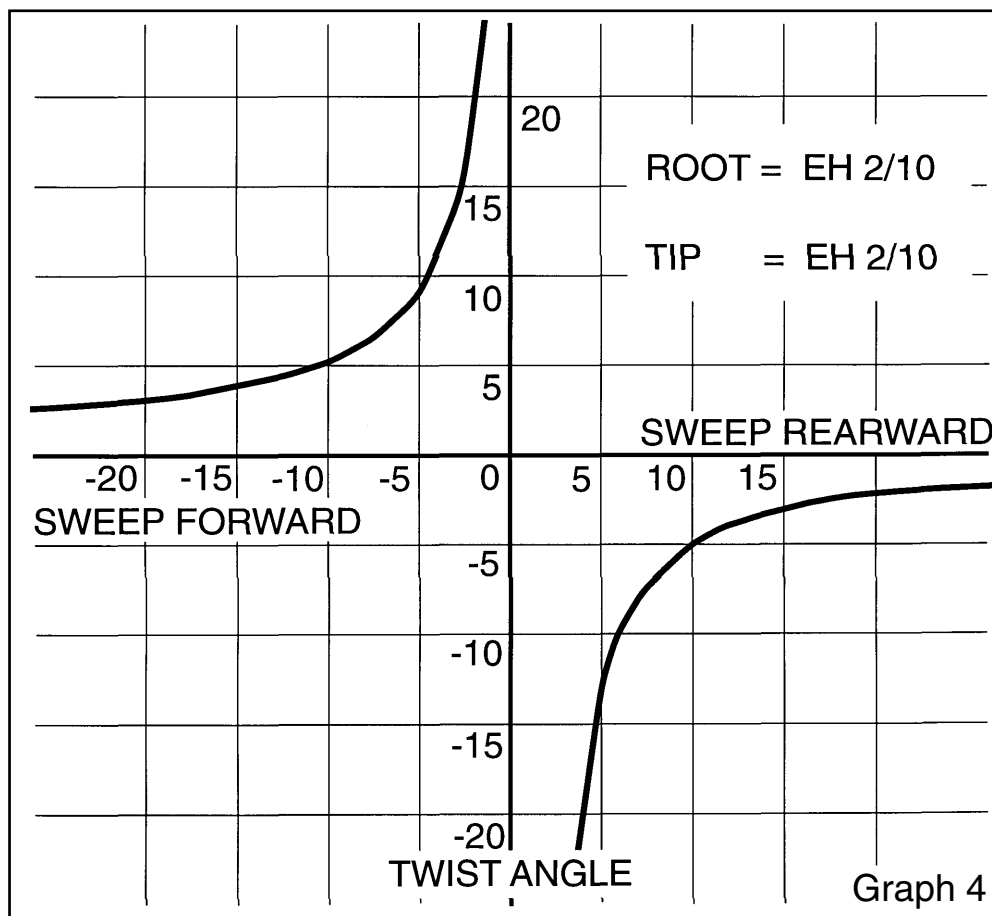

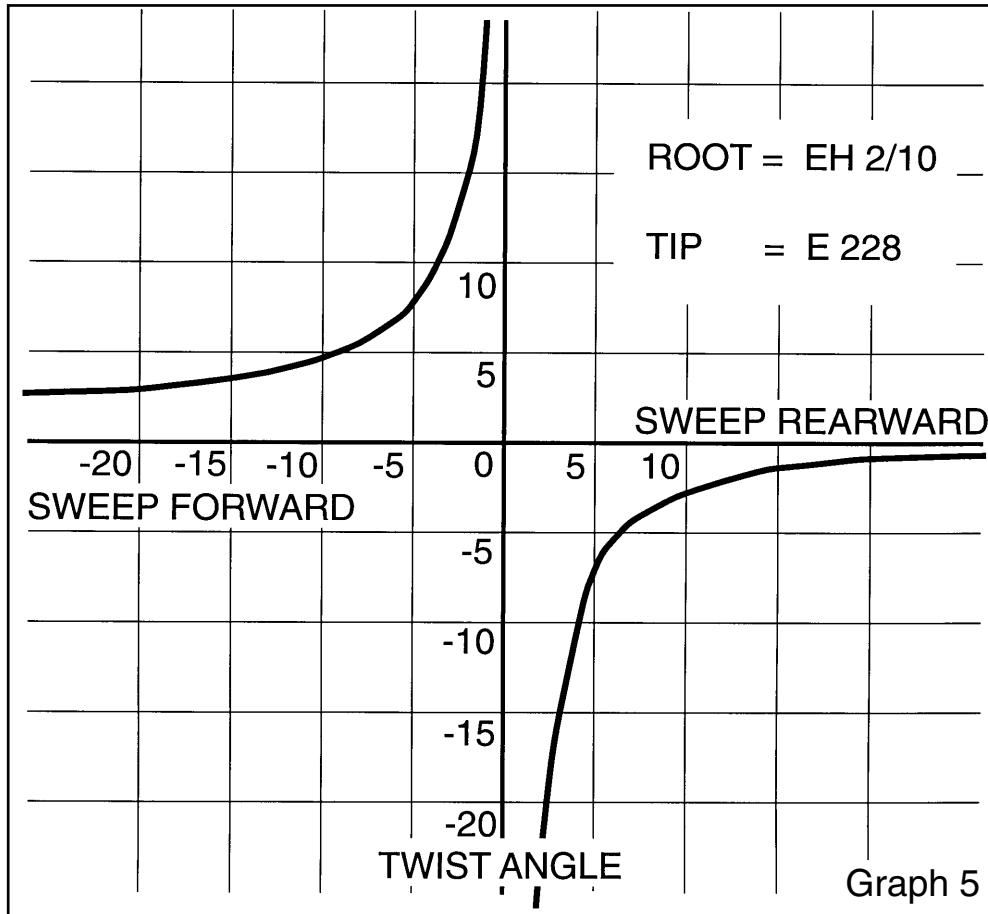

We previously noted a reduction in required wing twist when the inverted E 205 was substituted for the E 205 as the tip section. If the EH 2/10 is used at the root and a section with a substantial positive pitching moment is used for the tip, we can predict a similar reduction in required twist. Graph 5 depicts the case in which the root section is the EH 2/10 and the tip section is the E 228. (E 228: $C_m = +0.0143$, $\alpha_{10} = +0.34$)

The E 228, with its slightly positive pitching moment, is capable of providing a large stabilizing force at very low wing twist values. We would therefore expect to see twist requirements diminish further if the E 230 were used as the tip section. (E 230: $C_m = 0.025$, the pitching moment advocated by Dr. Panknin rather than the value published in MTB 1/2, $\alpha_{10} = 1.73$)

In Part 3 we'll tackle the case of the plank — the nonswept 'wing — and present some conclusions.

Part 3

All of the graphs shown so far point to markedly increased twist angles as sweep angle decreases, and so on the surface it appears a plank platform, that is a wing with no sweep of the quarter chord line (-1.15 degrees leading edge sweep in our example), is not possible. However, by incorporating wing twist into the airfoil section itself we neatly overcome this seeming difficulty.

To see how this works, we will use two reflexed sections with slightly different pitching moments, the E 228 and the E 230. (E 228: $C_m = +0.0143$, $\alpha_{l0} = +0.34$; E 230: $C_m = +0.025$, the pitching moment advocated by Dr. Panknin rather than the value published in MTB 1/2, $\alpha_{l0} = +1.73$) See Graphs 6 and 7, respectively.

These two graphs provide an interesting bit of information. The E 228 (Graph 6) requires washout (trailing edge up) for rearward sweep, as would be expected from what we've seen previously. This indicates the E 228 is not stable enough for a plank configuration with the static margin we've chosen. On the other hand, Graph 7 demonstrates the E 230 is actually too stable.

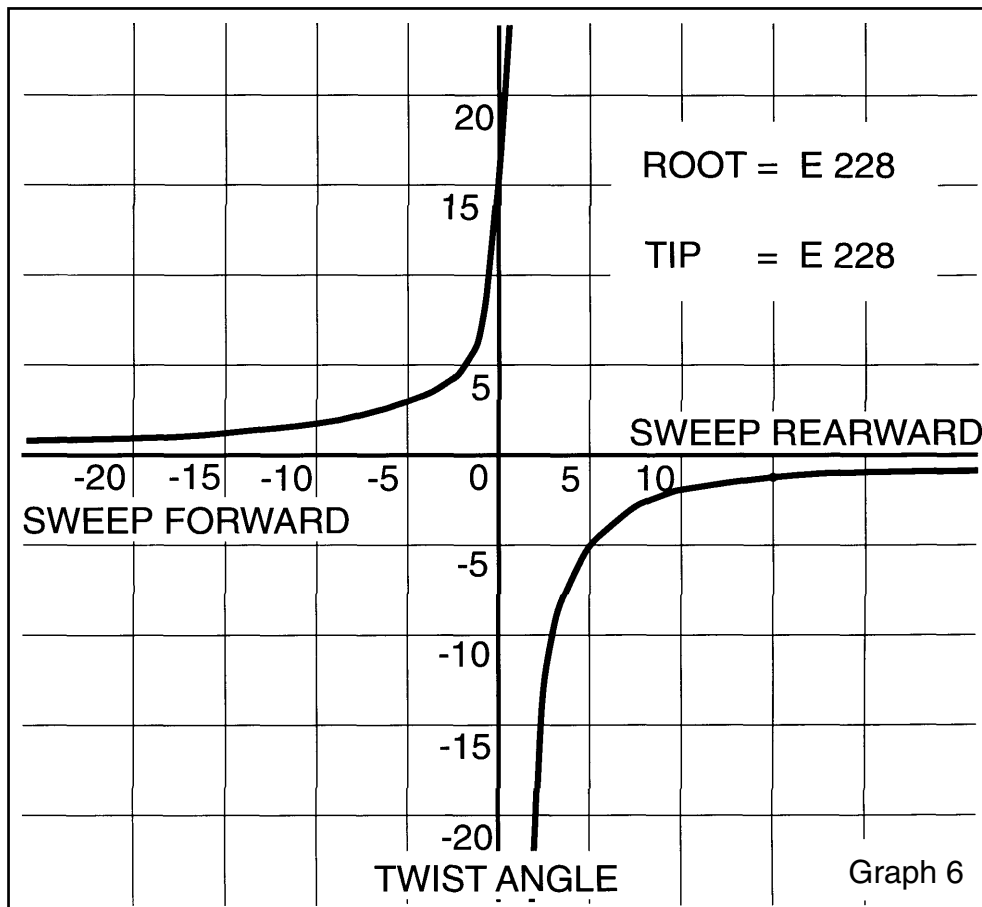

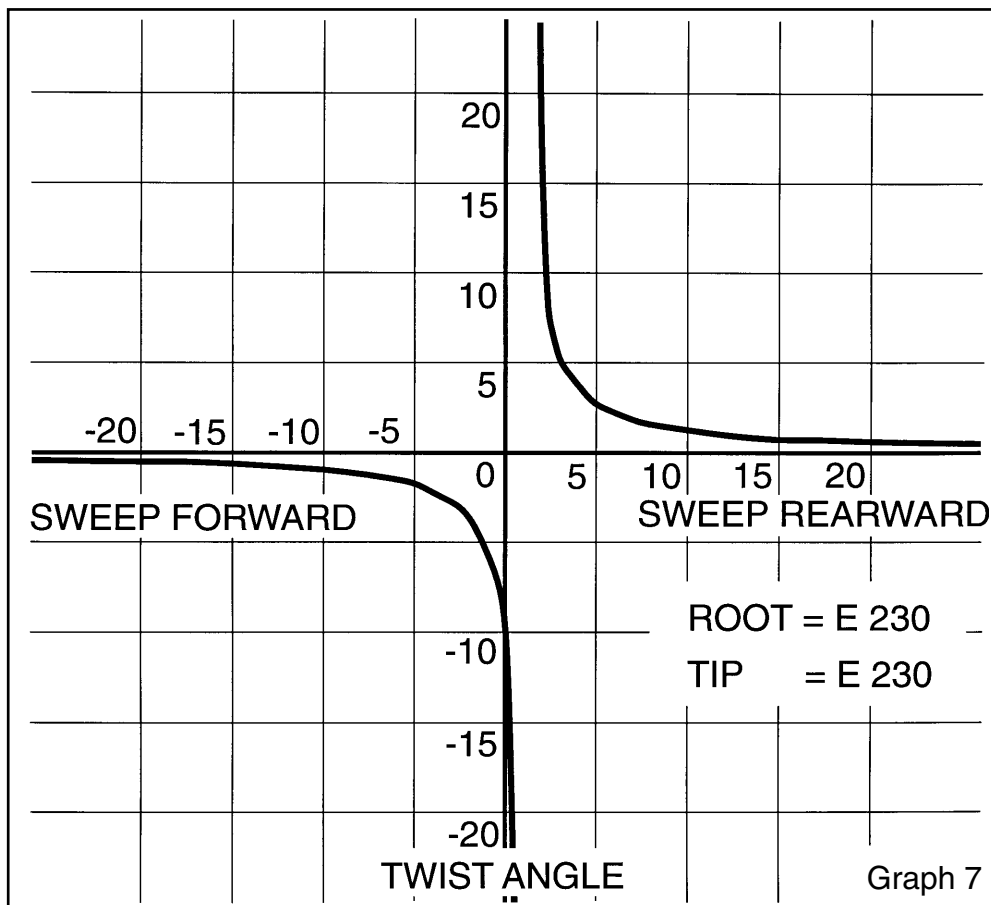

The graph shows the E 230 requires washin (trailing edge down) for rearward sweep! To achieve a stability factor of 0.035, the wing tip must actually provide an up force if the wing is swept back, and a down force if the wing is swept forward — just the opposite of what we've seen in all of the previous examples.

A plank planform with a stability factor of 0.035 and no sweep of the leading edge would, therefore, require an airfoil with a pitching moment between that of the E 228 and the E 230, but closer to the E 230. As an exercise, we computed the pitching moment required for this plank planform and stability factor; it turned out to be 0.021, as was intuitively anticipated. As a point of interest, the E 230, when used with the unswept plank planform described above, requires a stability factor of 0.04167.

A few closing notes are in order.

- Bill chose the 100 inch wing span based on performance, ease of transportation, and a large number of viable construction methods. For

those building other sizes, all linear dimensions can be easily proportioned, while all angles remain the same.

- We used a stability factor of 0.035 and an overall C_L of 0.6 for all of these examples. The required twist angle would increase in magnitude for a higher stability factor and larger C_L , and decrease in magnitude for a lower stability factor and smaller C_L value.
- While the stability factor is always directly related to both the location of the center of gravity and wing twist, changes in design C_L are related to wing twist only. We used a design C_L of 0.6 only for the purpose of constructing easily readable graphs. In the actual design process the C_L used in computations will be a fraction of this value and there will be an attendant lowering of the twist angle value.
- In practice, swept planforms have better performance than planks of the same dimensions. This is due to the inherent high drag of reflexed airfoils having markedly positive pitching moments. In designing a plank planform, therefore, you will want to use a reflexed section with no more reflex than necessary to provide a comfortable amount of stability. Additionally, swept wings tend to be more maneuverable than planks.
- Swept wings utilizing airfoils with pitching moments close to zero are now generally accepted to be the best performers, even though these sections do not have the lift capability of more conventional sections. A sweep angle of 15 to 20 degrees and a twist angle of less than four degrees are usually sufficient to provide needed stability when low pitching moment sections are used.
- For convenience, Table 3 provides the moment coefficient and zero lift angle data for the six airfoil sections mentioned in this series of articles
- The four basic concepts enumerated below should be an inherent part of the designer's knowledge base if an efficient design is to be the result.
 - (1) increased stability (a more forward CG) requires more twist
 - (2) a larger C_{mroot} requires more twist (We've now seen the C_{mtip} has an effect on the geometric twist required as well.)
 - (3) increased sweep angle lessens the amount of required twist
 - (4) a larger design C_L requires more twist
- As usual, we highly recommend readers explore avenues related to their own specific interests. This is an excellent learning environment which can provide much enjoyment.
- Lastly, a reminder for those of you with computers... Some time ago we wrote a BASIC program which determines both the required wing twist and

actual location of the center of gravity as measured from the apex of the leading edge. The program is available in printed form in the Appendix, but takes just a matter of minutes to type in. The code is available in Microsoft QuickBASIC for IBM compatibles and for the Macintosh OS.







REF	DESIGNATION	C_m	$\alpha_{l=0}$	SECTION PROFILE
1	E 205	-0.046	-2.37	
2	E 205.inv	+0.046	+2.37	
3	Symmetrical	0.000	0.00	
4	EH 2/10	+0.00165	-0.74	
5	E 228	+0.0143	+0.34	
6	E 230.Eppler/MTB 1/2	+0.053	+1.73	
7	E 230.Panknin	+0.025	+1.73	

Table 3

In this series of articles we have attempted to explain how the location of the center of gravity, the pitching moments of the airfoils used, the chosen sweep angle, and the design lift coefficient dictate wing twist and overall pitch stability. We have tried to limit our discussion to pitch stability as it relates to only these variables. We thus have not discussed control surfaces. A number of readers have inquired about this topic and asked us to include information about control surfaces: their types, sizes, shapes, locations and ranges of deflection. These topics will therefore be explored in future columns.

Prior to publication in *RCSD*, we printed a copy of this article and gave it to Bill Kubiak for comment. Next month we'll share his thoughts on the material presented.

Part 4

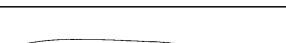
Parts 1, 2, and 3 of this series were printed and given to Bill Kubiak for comment. At the World Soaring Jamboree in Richland Washington, we spent quite a few pool-side hours going over the material, assuring ourselves of both its accuracy and logical presentation. Bill had brought along a written summary of his thoughts, and in going over what he had written, we decided it should be shared with RCSD readers.

“In trying to use the curves for design, I concluded that the nearer the arms of the curve are to the axes, the better. This is because we are looking for a minimum amount of wing twist. I also conclude that the further down into the corner of the X - Y axis the curves penetrate, the better. This is because we are looking for a reasonable sweep angle.

GRAPH #	ROOT SECTION	TIP SECTION
Graph 1	symmetrical	symmetrical
Graph 2	Eppler 205	Eppler 205
Graph 3	Eppler 205	inverted Eppler 205
Graph 4	EH 2/10	EH 2/10
Graph 5	EH 2/10	Eppler 228
Graph 6	Eppler 228	Eppler 228
Graph 7	Eppler 230	Eppler 230

“I had considerable trouble trying to compare one airfoil section to another, so I ran over to my favorite Mail Box and had transparent copies of your curves made. Then I laid the transparency of Graph 1 over that of Graph 4 and copied them onto plain paper. That’s better; now I can compare these two sections of similar (almost zero) C_m . I see that there is little to choose from between the two, at least as far as C_m is concerned. L/D should be looked at. I suspect the EH 2/10 will be better. After all, that’s the *raison d’etre* for camber, isn’t it?

“Then I stacked the transparencies of Graphs 1, 2, and 3 to see how a cambered section compared to a symmetrical section. Wow! I assume whatever the merits of the basic section are, if #3 is used, it being so far from the axis, trim drag will be excessive compared to #1. That’s why twisting a wing with a conventional cambered section just doesn’t work — the trim drag is too high. Now I understand, while before I didn’t. When you compare Graph #3 to both Graph #2 and Graph #1, you see that changing camber is a

more effective method of controlling C_M (pitching moment of the entire aircraft) than twist is.

“You could tune, through iteration, a design to fit a specific static margin by keeping a portion of the center section untwisted and just twisting the outer portion until the trim forces just balanced the static margin. However, the graphs show it is as easy to invert the tip section as to twist the wing.

“If a wing is built using the conventional hot wire and foam method, it is given a linear twist. I now realize that only the center line and the tip of such a wing will have known aerodynamic characteristics. In the case depicted in Graph #3, where the tip is inverted, the centerline section will gradually transition to a symmetrical section at near mid-semispan, which will then transition to the inverted section at the tip.

“Since every airfoil section has a design C_l , and you wish the design section C_l could be equal to the design C_L (whole aircraft) for minimum drag, it seems that for least drag for a given lift, as much of the wing should be untwisted as possible. Most of the wing is then flying at a constant C_L , hopefully at the design C_L .

“Now that I've decided that twist by itself is not the most efficient way of controlling the overall pitching moment (C_M), it makes sense to adopt the concept of inverting the tip section. At the time that you mentioned this to me I thought it was a real hokey way to solve a problem. Now I see that you could have the center section flying at its best design C_l , the tips flying at their best inverted design C_l , and the whole aircraft would be flying at the desired C_L .

“With all of this in mind, and when speaking of swept back wings, it seems what is very much needed is a root section with very low pitching moment but high $C_{l_{max}}$. The EH 2/10 is a far better choice for this application than a symmetrical section because it is capable of much greater lift with very little drag penalty. Since the root airfoil has a pitching moment near zero, the normal down force required by the wing tips is not great. On the other hand, you would want a tip section capable of high lift as well, since a strong up force is needed to right the aircraft in pitch following a stall of the center section. This leads me to believe it is best to choose an airfoil which meets all of these criteria and can be used across the entire span. My choice would be the EH 2/10.”

References:

Eppler Profile, MTB 1/2; Verlag für Technik und Handwerk GmbH,
Postfach 2274, 76492 Baden-Baden Germany.

Kuhlman, Bill and Bunny; "On the 'Wing...', the book"; B²Streamlines,
P.O. Box 976, Olalla WA 98359-0976.

Lichte, Dipl.-Ing. Martin; "Nurflügel-modelle," VTH Modellbaureihe Band 3;
Verlag für Technik und Handwerk GmbH, Postfach 2274, 76492
Baden-Baden Germany.

Panknin, Dr. Ing. Walter K.; "Proceedings, 1989 MARCS Symposium";
Allan Scidmore, 5013 Dorsett Drive, Madison WI 53711.

Tailless forever!

— Hans-Jürgen Unverferth